

Bta.

Barcelona tecnologías
de la alimentación

Barcelona food
technologies

FORMULARIO PESOS Y RESISTENCIA WEIGHT AND RESISTANCE FORM

Enviar la solicitud antes 04/05/2009 a:
To send before 04/05/2009 to:

Nº Fax: (+34) 93 5679683
E-mail: stecnico@alimentaria.com
www.bta-bcn.com

D. /Mr. :	Cargo / Job title :
Empresa / Company :	Stand Nº :
Dirección / Address :	C.P. / Z.P. :
Pob. / City:	País / Country:
Provincia / Country-State :	Tel./ Phone:
Fax :	E-mail :

CANTIDAD DE MAQUINAS A EXPONER
NUMBER OF MACHINE TO EXHIBIT

PREVISIÓN INICIO DE MONTAJE
BUILD UP FORESIGHT

Fecha/ Date: _____ Hora / Hour: _____

PREVISIÓN ENTRADA MAQUINARIA
MACHINERY ENTRANCE FORESIGHT

Fecha/ Date: _____ Hora / Hour: _____

METODO DE MANIPULACION DE MERCANCIAS
GOODS HANDLING WAY

DATOS MONTACARGAS - PABELLON 8.1 GV DETAILS OF GOODS LIFT - PAVILION 8.1 GV

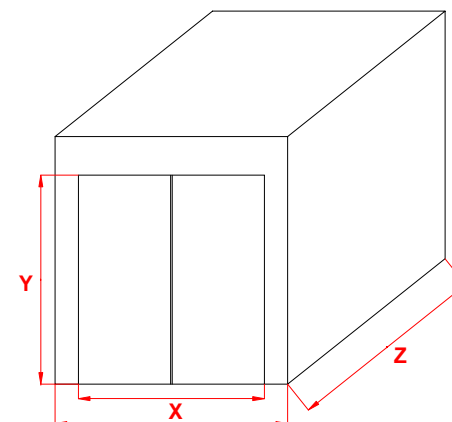

PESOS Y DIMENSIONES / WEIGHT AND DIMENSIONS

MAQUINA / MACHINE	PESO / WEIGHT (Kg)	DIMENSIONES / DIMENSIONS (m) Ancho/Width x Largo/Length
1		
2		
3		
4		
5		

Montacargas Nº Lift Nº	Peso máximo Max. Weight (Kg)	Dimensiones Plataforma / Interior Dimensions (X x Z)	Dimensiones luz Puerta / Door Dimensions (X x Y)
8.1	4000	3000 x 3990	2700 x 2200
8.2	6000	3000 x 5750	2700 x 2800
8.3	4000	3000 x 3990	2800 x 2400
8.4	6000	3000 x 5750	2700 x 2800
8.5	6000	3000 x 5750	2700 x 2800

Les aconsejamos planifiquen con la máxima antelación la entrada de la maquinaria para la exposición.
Companies exhibiting machinery are advised to deliver their goods in as early as possible.